

EQUIPOS CE

→ Equipo simple formado por una bomba principal eléctrica.

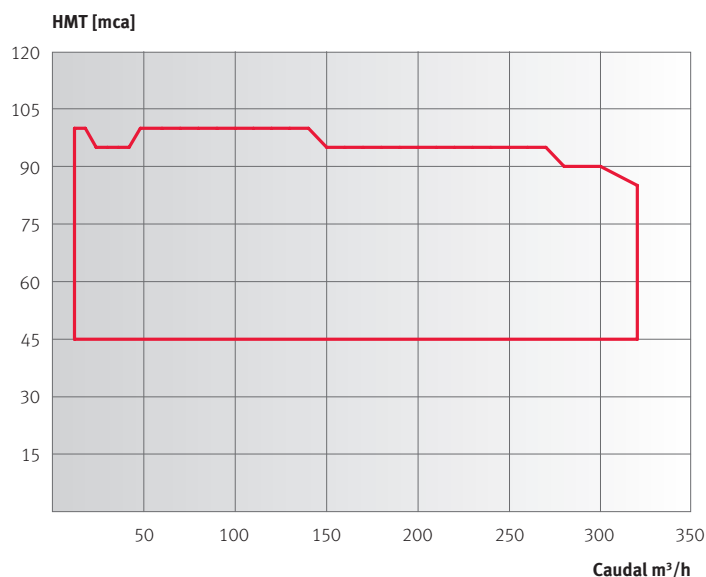
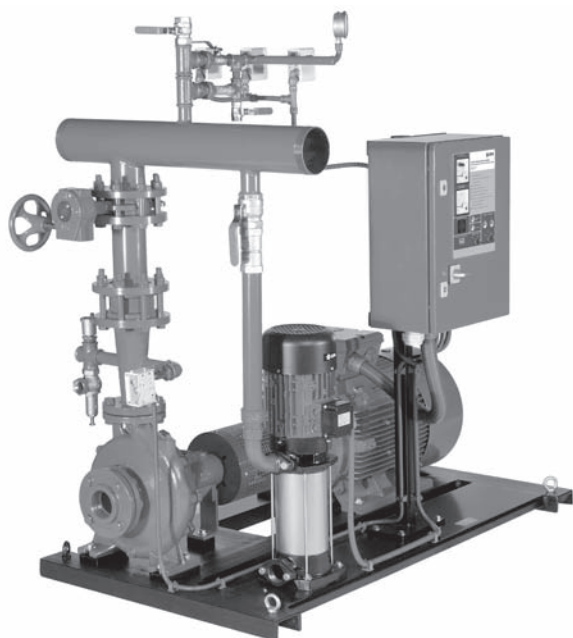

FORMA CONSTRUCTIVA EQUIPOS CE

1) Auxiliar: Electrobomba vertical multicelular del modelo MULTI 35 6, MULTI 35 8 o MULTI 35 10.

2) Bomba Servicio: Bomba de la serie BN en ejecución eje libre construida según las directrices de la norma EN733. Dispone de rodete en bronce y de la camisa del eje y el eje en acero inoxidable.

3) Motor Eléctrico: Horizontal con refrigeración IP55 en forma constructiva B-3. Unido a la parte hidráulica mediante acoplamiento con distanciador.

4) Colector y Valvulería: Colector de diámetro nominal diseñado para garantizar una circulación máxima de fluido de 2 m/s. Válvula de retención de mariposa. Válvula de cierre tipo mariposa con volante desmultiplicador.

5) Instrumentación: Tres presostatos del tipo normalmente abierto. Manómetro de glicerina de fondo de escala adecuado a la presión máxima del equipo. Colector de instrumentos con válvula de aislamiento para favorecer las operaciones de mantenimiento, válvula de retención instalada en paralelo y válvula de desagüe para prueba de presostatos.

6) Cuadro Eléctrico: Armario metálico de color rojo con interruptor general de corte. Preparado para cumplir todos los requisitos de la regla técnica Cepenven.

7) Acabado y Cableado: Pintado en rojo RAL 3000 CC. Cableado y probado.

8) Accesorios Opcionales: Circuito de pruebas con caudalímetro, de obligada colocación según el párrafo 4.2.3.3 de la norma RT2-ABA de Cepenven. Sistema de cebado de obligada colocación en aspiraciones negativas según el párrafo 4.2.3.4 de dicha norma.

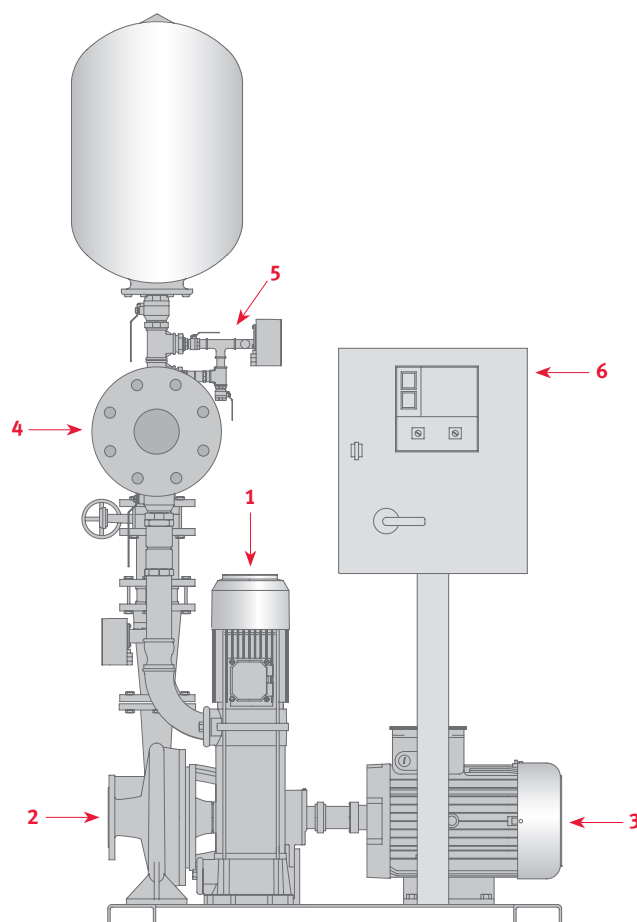

Ejecución:

Tipo 16

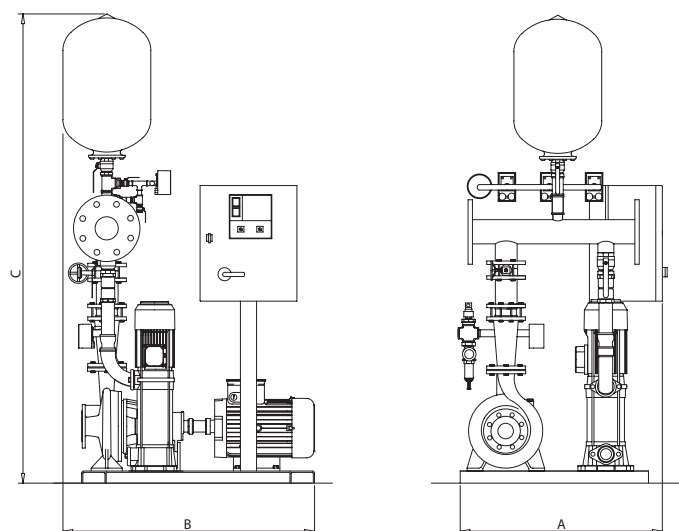

| EQUIPO | Bomba Auxiliar | | Bomba Servicio | | | Bomba Emergencia | | | Diámetro colector | Diámetro valvulería | Modelo calderín | DIMENSIONES | | | Ejecución |
|-----------|----------------|-----|----------------|-------|-----|------------------|-------|-----|-------------------|---------------------|-----------------|-------------|-------|-------|-----------|
| | Modelo | HP | Modelo | Motor | HP | Modelo | Motor | HP | | | | A | B | C | |
| CE 12/45 | MULTI 35 6 | 3 | B 32-200 | E | 7,5 | ***** | *** | *** | 3" | 2" | 24 AMR 8 | 900 | 1.300 | 1.700 | 16 |
| CE 12/50 | MULTI 35 6 | 3 | B 32-200 | E | 10 | ***** | *** | *** | 3" | 2" | 24 AMR 8 | 900 | 1.300 | 1.700 | 16 |
| CE 12/55 | MULTI 35 6 | 3 | B 32-200 | E | 10 | ***** | *** | *** | 3" | 2" | 24 AMR 8 | 900 | 1.300 | 1.700 | 16 |
| CE 12/60 | MULTI 35 6 | 3 | B 32-200 | E | 15 | ***** | *** | *** | 3" | 2" | 24 AMR 8 | 900 | 1.300 | 1.700 | 16 |
| CE 12/65 | MULTI 35 6 | 3 | B 32-250 | E | 15 | ***** | *** | *** | 3" | 2" | 24 AMR 8 | 900 | 1.300 | 1.700 | 16 |
| CE 12/70 | MULTI 35 8 | 4 | B 32-250 | E | 15 | ***** | *** | *** | 3" | 2" | 50 AMR 10 | 900 | 1.300 | 1.700 | 16 |
| CE 12/75 | MULTI 35 8 | 4 | B 32-250 | E | 15 | ***** | *** | *** | 3" | 2" | 50 AMR 10 | 900 | 1.300 | 1.700 | 16 |
| CE 12/80 | MULTI 35 8 | 4 | B 32-250 | E | 15 | ***** | *** | *** | 3" | 2" | 50 AMR 10 | 900 | 1.300 | 1.700 | 16 |
| CE 12/85 | MULTI 35 8 | 4 | B 32-250 | E | 20 | ***** | *** | *** | 3" | 2" | 50 AMR 10 | 900 | 1.300 | 1.700 | 16 |
| CE 12/90 | MULTI 35 8 | 4 | B 32-250 | E | 20 | ***** | *** | *** | 3" | 2" | 50 AMR 10 | 900 | 1.300 | 1.700 | 16 |
| CE 12/95 | MULTI 35 10 | 5,5 | B 32-250 | E | 20 | ***** | *** | *** | 3" | 2" | 50 AMR 16 | 900 | 1.300 | 1.700 | 16 |
| CE 12/100 | MULTI 35 10 | 5,5 | B 32-250 | E | 25 | ***** | *** | *** | 3" | 2" | 50 AMR 16 | 900 | 1.300 | 1.700 | 16 |
| CE 18/45 | MULTI 35 6 | 3 | B 32-200 | E | 10 | ***** | *** | *** | 3" | 2 1/2" | 24 AMR 8 | 900 | 1.300 | 1.700 | 16 |
| CE 18/50 | MULTI 35 6 | 3 | B 32-200 | E | 10 | ***** | *** | *** | 3" | 2 1/2" | 24 AMR 8 | 900 | 1.300 | 1.700 | 16 |
| CE 18/55 | MULTI 35 6 | 3 | B 32-200 | E | 15 | ***** | *** | *** | 3" | 2 1/2" | 24 AMR 8 | 900 | 1.300 | 1.700 | 16 |
| CE 18/60 | MULTI 35 6 | 3 | B 32-200 | E | 15 | ***** | *** | *** | 3" | 2 1/2" | 24 AMR 8 | 900 | 1.300 | 1.700 | 16 |
| CE 18/65 | MULTI 35 6 | 3 | B 32-250 | E | 15 | ***** | *** | *** | 3" | 2 1/2" | 24 AMR 8 | 900 | 1.300 | 1.700 | 16 |
| CE 18/70 | MULTI 35 8 | 4 | B 32-250 | E | 15 | ***** | *** | *** | 3" | 2 1/2" | 50 AMR 10 | 900 | 1.300 | 1.700 | 16 |
| CE 18/75 | MULTI 35 8 | 4 | B 32-250 | E | 15 | ***** | *** | *** | 3" | 2 1/2" | 50 AMR 10 | 900 | 1.300 | 1.700 | 16 |
| CE 18/80 | MULTI 35 8 | 4 | B 32-250 | E | 20 | ***** | *** | *** | 3" | 2 1/2" | 50 AMR 10 | 900 | 1.300 | 1.700 | 16 |
| CE 18/85 | MULTI 35 8 | 4 | B 32-250 | E | 20 | ***** | *** | *** | 3" | 2 1/2" | 50 AMR 10 | 900 | 1.300 | 1.700 | 16 |
| CE 18/90 | MULTI 35 8 | 4 | B 32-250 | E | 20 | ***** | *** | *** | 3" | 2 1/2" | 50 AMR 10 | 900 | 1.300 | 1.700 | 16 |
| CE 18/95 | MULTI 35 10 | 5,5 | B 32-250 | E | 20 | ***** | *** | *** | 3" | 2 1/2" | 50 AMR 16 | 900 | 1.300 | 1.700 | 16 |
| CE 18/100 | MULTI 35 10 | 5,5 | B 32-250 | E | 25 | ***** | *** | *** | 3" | 2 1/2" | 50 AMR 16 | 900 | 1.300 | 1.700 | 16 |
| CE 24/45 | MULTI 35 6 | 3 | B 32-200 | E | 15 | ***** | *** | *** | 3" | 2 1/2" | 24 AMR 8 | 900 | 1.300 | 1.700 | 16 |
| CE 24/50 | MULTI 35 6 | 3 | B 32-200 | E | 15 | ***** | *** | *** | 3" | 2 1/2" | 24 AMR 8 | 900 | 1.300 | 1.700 | 16 |
| CE 24/55 | MULTI 35 6 | 3 | B 32-200 | E | 15 | ***** | *** | *** | 3" | 2 1/2" | 24 AMR 8 | 900 | 1.300 | 1.700 | 16 |
| CE 24/60 | MULTI 35 6 | 3 | B 40-250 | E | 15 | ***** | *** | *** | 3" | 2 1/2" | 24 AMR 8 | 900 | 1.300 | 1.700 | 16 |
| CE 24/65 | MULTI 35 6 | 3 | B 40-250 | E | 20 | ***** | *** | *** | 3" | 2 1/2" | 24 AMR 8 | 900 | 1.300 | 1.700 | 16 |
| CE 24/70 | MULTI 35 8 | 4 | B 40-250 | E | 20 | ***** | *** | *** | 3" | 2 1/2" | 50 AMR 10 | 900 | 1.300 | 1.700 | 16 |
| CE 24/75 | MULTI 35 8 | 4 | B 40-250 | E | 20 | ***** | *** | *** | 3" | 2 1/2" | 50 AMR 10 | 900 | 1.300 | 1.700 | 16 |
| CE 24/80 | MULTI 35 8 | 4 | B 40-250 | E | 25 | ***** | *** | *** | 3" | 2 1/2" | 50 AMR 10 | 900 | 1.300 | 1.700 | 16 |
| CE 24/85 | MULTI 35 8 | 4 | B 40-250 | E | 30 | ***** | *** | *** | 3" | 2 1/2" | 50 AMR 10 | 900 | 1.300 | 1.700 | 16 |
| CE 24/90 | MULTI 35 8 | 4 | B 40-250 | E | 30 | ***** | *** | *** | 3" | 2 1/2" | 50 AMR 10 | 900 | 1.300 | 1.700 | 16 |
| CE 24/95 | MULTI 35 10 | 5,5 | B 40-250 | E | 30 | ***** | *** | *** | 3" | 2 1/2" | 50 AMR 16 | 900 | 1.300 | 1.700 | 16 |

| EQUIPO | Bomba Auxiliar | | Bomba Servicio | | | Bomba Emergencia | | | Diámetro colector | Diámetro valvulería | Modelo calderín | DIMENSIONES | | | Ejecución |
|-----------|----------------|-----|----------------|-------|----|------------------|-------|-----|-------------------|---------------------|-----------------|-------------|-------|-------|-----------|
| | Modelo | HP | Modelo | Motor | HP | Modelo | Motor | HP | | | | A | B | C | |
| CE 24/100 | MULTI 35 10 | 5,5 | consultar | | | ***** | *** | *** | 3" | 2 1/2" | 50 AMR 16 | | | | 16 |
| CE 30/45 | MULTI 35 6 | 3 | B 40-200 | E | 10 | ***** | *** | *** | 4" | 3" | 24 AMR 8 | 900 | 1.300 | 1.700 | 16 |
| CE 30/50 | MULTI 35 6 | 3 | B 40-200 | E | 15 | ***** | *** | *** | 4" | 3" | 24 AMR 8 | 900 | 1.300 | 1.700 | 16 |
| CE 30/55 | MULTI 35 6 | 3 | B 40-200 | E | 15 | ***** | *** | *** | 4" | 3" | 24 AMR 8 | 900 | 1.300 | 1.700 | 16 |
| CE 30/60 | MULTI 35 6 | 3 | B 40-250 | E | 15 | ***** | *** | *** | 4" | 3" | 24 AMR 8 | 900 | 1.300 | 1.700 | 16 |
| CE 30/65 | MULTI 35 6 | 3 | B 40-250 | E | 20 | ***** | *** | *** | 4" | 3" | 24 AMR 8 | 900 | 1.300 | 1.700 | 16 |
| CE 30/70 | MULTI 35 8 | 4 | B 40-250 | E | 20 | ***** | *** | *** | 4" | 3" | 50 AMR 10 | 900 | 1.300 | 1.700 | 16 |
| CE 30/75 | MULTI 35 8 | 4 | B 40-250 | E | 25 | ***** | *** | *** | 4" | 3" | 50 AMR 10 | 900 | 1.300 | 1.700 | 16 |
| CE 30/80 | MULTI 35 8 | 4 | B 40-250 | E | 25 | ***** | *** | *** | 4" | 3" | 50 AMR 10 | 900 | 1.300 | 1.700 | 16 |
| CE 30/85 | MULTI 35 8 | 4 | B 40-250 | E | 30 | ***** | *** | *** | 4" | 3" | 50 AMR 10 | 900 | 1.300 | 1.700 | 16 |
| CE 30/90 | MULTI 35 8 | 4 | B 40-250 | E | 30 | ***** | *** | *** | 4" | 3" | 50 AMR 10 | 900 | 1.300 | 1.700 | 16 |
| CE 30/95 | MULTI 35 10 | 5,5 | B 40-250 | E | 30 | ***** | *** | *** | 4" | 3" | 50 AMR 16 | 900 | 1.300 | 1.700 | 16 |
| CE 30/100 | MULTI 35 10 | 5,5 | consultar | | | ***** | *** | *** | 4" | 3" | 50 AMR 16 | | | | 16 |
| CE 36/45 | MULTI 35 6 | 3 | B 40-200 | E | 15 | ***** | *** | *** | 4" | 3" | 24 AMR 8 | 900 | 1.300 | 1.700 | 16 |
| CE 36/50 | MULTI 35 6 | 3 | B 40-200 | E | 15 | ***** | *** | *** | 4" | 3" | 24 AMR 8 | 900 | 1.300 | 1.700 | 16 |
| CE 36/55 | MULTI 35 6 | 3 | B 40-250 | E | 15 | ***** | *** | *** | 4" | 3" | 24 AMR 8 | 900 | 1.300 | 1.700 | 16 |
| CE 36/60 | MULTI 35 6 | 3 | B 40-250 | E | 20 | ***** | *** | *** | 4" | 3" | 24 AMR 8 | 900 | 1.300 | 1.700 | 16 |
| CE 36/65 | MULTI 35 6 | 3 | B 40-250 | E | 20 | ***** | *** | *** | 4" | 3" | 24 AMR 8 | 900 | 1.300 | 1.700 | 16 |
| CE 36/70 | MULTI 35 8 | 4 | B 40-250 | E | 20 | ***** | *** | *** | 4" | 3" | 50 AMR 10 | 900 | 1.300 | 1.700 | 16 |
| CE 36/75 | MULTI 35 8 | 4 | B 40-250 | E | 25 | ***** | *** | *** | 4" | 3" | 50 AMR 10 | 900 | 1.300 | 1.700 | 16 |
| CE 36/80 | MULTI 35 8 | 4 | B 40-250 | E | 30 | ***** | *** | *** | 4" | 3" | 50 AMR 10 | 900 | 1.300 | 1.700 | 16 |
| CE 36/85 | MULTI 35 8 | 4 | B 40-250 | E | 30 | ***** | *** | *** | 4" | 3" | 50 AMR 10 | 900 | 1.300 | 1.700 | 16 |
| CE 36/90 | MULTI 35 8 | 4 | B 40-250 | E | 30 | ***** | *** | *** | 4" | 3" | 50 AMR 10 | 900 | 1.300 | 1.700 | 16 |
| CE 36/95 | MULTI 35 10 | 5,5 | B 40-250 | E | 40 | ***** | *** | *** | 4" | 3" | 50 AMR 16 | 1.000 | 1.600 | 2.000 | 16 |
| CE 36/100 | MULTI 35 10 | 5,5 | consultar | | | ***** | *** | *** | 4" | 3" | 50 AMR 16 | | | | 16 |
| CE 40/45 | MULTI 35 6 | 3 | B 40-160 | E | 15 | ***** | *** | *** | 4" | 3" | 24 AMR 8 | 900 | 1.300 | 1.700 | 16 |
| CE 40/50 | MULTI 35 6 | 3 | B 40-200 | E | 15 | ***** | *** | *** | 4" | 3" | 24 AMR 8 | 900 | 1.300 | 1.700 | 16 |
| CE 40/55 | MULTI 35 6 | 3 | B 50-200 | E | 20 | ***** | *** | *** | 4" | 3" | 24 AMR 8 | 900 | 1.300 | 1.700 | 16 |
| CE 40/60 | MULTI 35 6 | 3 | B 50-200 | E | 25 | ***** | *** | *** | 4" | 3" | 24 AMR 8 | 900 | 1.300 | 1.700 | 16 |
| CE 40/65 | MULTI 35 6 | 3 | B 50-200 | E | 25 | ***** | *** | *** | 4" | 3" | 24 AMR 8 | 900 | 1.300 | 1.700 | 16 |
| CE 40/70 | MULTI 35 8 | 4 | B 40-250 | E | 25 | ***** | *** | *** | 4" | 3" | 50 AMR 10 | 900 | 1.300 | 1.700 | 16 |
| CE 40/75 | MULTI 35 8 | 4 | B 40-250 | E | 25 | ***** | *** | *** | 4" | 3" | 50 AMR 10 | 900 | 1.300 | 1.700 | 16 |
| CE 40/80 | MULTI 35 8 | 4 | B 40-250 | E | 30 | ***** | *** | *** | 4" | 3" | 50 AMR 10 | 900 | 1.300 | 1.700 | 16 |
| CE 40/85 | MULTI 35 8 | 4 | B 40-250 | E | 30 | ***** | *** | *** | 4" | 3" | 50 AMR 10 | 900 | 1.300 | 1.700 | 16 |
| CE 40/90 | MULTI 35 8 | 4 | B 40-250 | E | 30 | ***** | *** | *** | 4" | 3" | 50 AMR 10 | 900 | 1.300 | 1.700 | 16 |
| CE 40/95 | MULTI 35 10 | 5,5 | B 50-250 | E | 50 | ***** | *** | *** | 4" | 3" | 50 AMR 16 | 1.000 | 1.600 | 2.000 | 16 |
| CE 40/100 | MULTI 35 10 | 5,5 | consultar | | | ***** | *** | *** | 4" | 3" | 50 AMR 16 | | | | 16 |
| CE 50/45 | MULTI 35 6 | 3 | B 50-160 | E | 20 | ***** | *** | *** | 4" | 3" | 24 AMR 8 | 900 | 1.300 | 1.700 | 16 |
| CE 50/50 | MULTI 35 6 | 3 | B 50-200 | E | 20 | ***** | *** | *** | 4" | 3" | 24 AMR 8 | 900 | 1.300 | 1.700 | 16 |
| CE 50/55 | MULTI 35 6 | 3 | B 50-200 | E | 20 | ***** | *** | *** | 4" | 3" | 24 AMR 8 | 900 | 1.300 | 1.700 | 16 |
| CE 50/60 | MULTI 35 6 | 3 | B 50-200 | E | 25 | ***** | *** | *** | 4" | 3" | 24 AMR 8 | 900 | 1.300 | 1.700 | 16 |
| CE 50/65 | MULTI 35 6 | 3 | B 50-200 | E | 25 | ***** | *** | *** | 4" | 3" | 24 AMR 8 | 900 | 1.300 | 1.700 | 16 |
| CE 50/70 | MULTI 35 8 | 4 | B 50-250 | E | 30 | ***** | *** | *** | 4" | 3" | 50 AMR 10 | 900 | 1.300 | 1.700 | 16 |
| CE 50/75 | MULTI 35 8 | 4 | B 50-250 | E | 40 | ***** | *** | *** | 4" | 3" | 50 AMR 10 | 1.000 | 1.600 | 2.000 | 16 |
| CE 50/80 | MULTI 35 8 | 4 | B 50-250 | E | 40 | ***** | *** | *** | 4" | 3" | 50 AMR 10 | 1.000 | 1.600 | 2.000 | 16 |
| CE 50/85 | MULTI 35 8 | 4 | B 50-250 | E | 40 | ***** | *** | *** | 4" | 3" | 50 AMR 10 | 1.000 | 1.600 | 2.000 | 16 |
| CE 50/90 | MULTI 35 8 | 4 | B 50-250 | E | 50 | ***** | *** | *** | 4" | 3" | 50 AMR 10 | 1.000 | 1.600 | 2.000 | 16 |
| CE 50/95 | MULTI 35 10 | 5,5 | B 50-250 | E | 50 | ***** | *** | *** | 4" | 3" | 50 AMR 16 | 1.000 | 1.600 | 2.000 | 16 |
| CE 50/100 | MULTI 35 10 | 5,5 | B 50-250 | E | 60 | ***** | *** | *** | 4" | 3" | 50 AMR 16 | 1.000 | 1.600 | 2.000 | 16 |
| CE 60/45 | MULTI 35 6 | 3 | B 50-160 | E | 20 | ***** | *** | *** | 5" | 4" | 24 AMR 8 | 900 | 1.300 | 1.700 | 16 |
| CE 60/50 | MULTI 35 6 | 3 | B 50-200 | E | 20 | ***** | *** | *** | 5" | 4" | 24 AMR 8 | 900 | 1.300 | 1.700 | 16 |
| CE 60/55 | MULTI 35 6 | 3 | B 50-200 | E | 25 | ***** | *** | *** | 5" | 4" | 24 AMR 8 | 900 | 1.300 | 1.700 | 16 |
| CE 60/60 | MULTI 35 6 | 3 | B 50-200 | E | 30 | ***** | *** | *** | 5" | 4" | 24 AMR 8 | 900 | 1.300 | 1.700 | 16 |
| CE 60/65 | MULTI 35 6 | 3 | B 50-250 | E | 30 | ***** | *** | *** | 5" | 4" | 24 AMR 8 | 900 | 1.300 | 1.700 | 16 |
| CE 60/70 | MULTI 35 8 | 4 | B 50-250 | E | 40 | ***** | *** | *** | 5" | 4" | 50 AMR 10 | 1.000 | 1.600 | 2.000 | 16 |
| CE 60/75 | MULTI 35 8 | 4 | B 50-250 | E | 40 | ***** | *** | *** | 5" | 4" | 50 AMR 10 | 1.000 | 1.600 | 2.000 | 16 |
| CE 60/80 | MULTI 35 8 | 4 | B 50-250 | E | 40 | ***** | *** | *** | 5" | 4" | 50 AMR 10 | 1.000 | 1.600 | 2.000 | 16 |
| CE 60/85 | MULTI 35 8 | 4 | B 50-250 | E | 50 | ***** | *** | *** | 5" | 4" | 50 AMR 10 | 1.000 | 1.600 | 2.000 | 16 |
| CE 60/90 | MULTI 35 8 | 4 | B 50-250 | E | 50 | ***** | *** | *** | 5" | 4" | 50 AMR 10 | 1.000 | 1.600 | 2.000 | 16 |

| EQUIPO | Bomba Auxiliar | | Bomba Servicio | | | Bomba Emergencia | | | Diámetro colector | Diámetro valvulería | Modelo calderín | DIMENSIONES | | | Ejecución Tipo |
|------------|----------------|-----|----------------|-------|----|------------------|-------|-----|-------------------|---------------------|-----------------|-------------|-------|-------|-------------------|
| | Modelo | HP | Modelo | Motor | HP | Modelo | Motor | HP | | | | A | B | C | |
| CE 60/95 | MULTI 35 10 | 5,5 | B 50-250 | E | 60 | ***** | *** | *** | 5" | 4" | 50 AMR 16 | 1.000 | 1.600 | 2.000 | 16 |
| CE 60/100 | MULTI 35 10 | 5,5 | B 50-250 | E | 60 | ***** | *** | *** | 5" | 4" | 50 AMR 16 | 1.000 | 1.600 | 2.000 | 16 |
| CE 70/45 | MULTI 35 6 | 3 | B 50-200 | E | 20 | ***** | *** | *** | 5" | 4" | 24 AMR 8 | 900 | 1.300 | 1.700 | 16 |
| CE 70/50 | MULTI 35 6 | 3 | B 50-200 | E | 25 | ***** | *** | *** | 5" | 4" | 24 AMR 8 | 900 | 1.300 | 1.700 | 16 |
| CE 70/55 | MULTI 35 6 | 3 | B 50-200 | E | 25 | ***** | *** | *** | 5" | 4" | 24 AMR 8 | 900 | 1.300 | 1.700 | 16 |
| CE 70/60 | MULTI 35 6 | 3 | B 50-200 | E | 30 | ***** | *** | *** | 5" | 4" | 24 AMR 8 | 900 | 1.300 | 1.700 | 16 |
| CE 70/65 | MULTI 35 6 | 3 | B 65-200 | E | 40 | ***** | *** | *** | 5" | 4" | 24 AMR 8 | 1.000 | 1.600 | 2.000 | 16 |
| CE 70/70 | MULTI 35 8 | 4 | B 65-250 | E | 40 | ***** | *** | *** | 5" | 4" | 50 AMR 10 | 1.000 | 1.600 | 2.000 | 16 |
| CE 70/75 | MULTI 35 8 | 4 | B 65-250 | E | 40 | ***** | *** | *** | 5" | 4" | 50 AMR 10 | 1.000 | 1.600 | 2.000 | 16 |
| CE 70/80 | MULTI 35 8 | 4 | B 50-250 | E | 40 | ***** | *** | *** | 5" | 4" | 50 AMR 10 | 1.000 | 1.600 | 2.000 | 16 |
| CE 70/85 | MULTI 35 8 | 4 | B 50-250 | E | 50 | ***** | *** | *** | 5" | 4" | 50 AMR 10 | 1.000 | 1.600 | 2.000 | 16 |
| CE 70/90 | MULTI 35 8 | 4 | B 50-250 | E | 50 | ***** | *** | *** | 5" | 4" | 50 AMR 10 | 1.000 | 1.600 | 2.000 | 16 |
| CE 70/95 | MULTI 35 10 | 5,5 | B 50-250 | E | 60 | ***** | *** | *** | 5" | 4" | 50 AMR 16 | 1.000 | 1.600 | 2.000 | 16 |
| CE 70/100 | MULTI 35 10 | 5,5 | B 65-250 | E | 75 | ***** | *** | *** | 5" | 4" | 50 AMR 16 | 1.300 | 2.100 | 2.300 | 16 |
| CE 80/45 | MULTI 35 6 | 3 | B 65-200 | E | 25 | ***** | *** | *** | 5" | 4" | 24 AMR 8 | 900 | 1.300 | 1.700 | 16 |
| CE 80/50 | MULTI 35 6 | 3 | B 65-200 | E | 25 | ***** | *** | *** | 5" | 4" | 24 AMR 8 | 900 | 1.300 | 1.700 | 16 |
| CE 80/55 | MULTI 35 6 | 3 | B 50-200 | E | 30 | ***** | *** | *** | 5" | 4" | 24 AMR 8 | 900 | 1.300 | 1.700 | 16 |
| CE 80/60 | MULTI 35 6 | 3 | B 65-200 | E | 40 | ***** | *** | *** | 5" | 4" | 24 AMR 8 | 1.000 | 1.600 | 2.000 | 16 |
| CE 80/65 | MULTI 35 6 | 3 | B 65-200 | E | 40 | ***** | *** | *** | 5" | 4" | 24 AMR 8 | 1.000 | 1.600 | 2.000 | 16 |
| CE 80/70 | MULTI 35 8 | 4 | B 65-250 | E | 40 | ***** | *** | *** | 5" | 4" | 50 AMR 10 | 1.000 | 1.600 | 2.000 | 16 |
| CE 80/75 | MULTI 35 8 | 4 | B 65-250 | E | 50 | ***** | *** | *** | 5" | 4" | 50 AMR 10 | 1.000 | 1.600 | 2.000 | 16 |
| CE 80/80 | MULTI 35 8 | 4 | B 65-250 | E | 50 | ***** | *** | *** | 5" | 4" | 50 AMR 10 | 1.000 | 1.600 | 2.000 | 16 |
| CE 80/85 | MULTI 35 8 | 4 | B 65-250 | E | 60 | ***** | *** | *** | 5" | 4" | 50 AMR 10 | 1.000 | 1.600 | 2.000 | 16 |
| CE 80/90 | MULTI 35 8 | 4 | B 50-250 | E | 60 | ***** | *** | *** | 5" | 4" | 50 AMR 10 | 1.000 | 1.600 | 2.000 | 16 |
| CE 80/95 | MULTI 35 10 | 5,5 | B 50-250 | E | 60 | ***** | *** | *** | 5" | 4" | 50 AMR 16 | 1.000 | 1.600 | 2.000 | 16 |
| CE 80/100 | MULTI 35 10 | 5,5 | B 65-250 | E | 75 | ***** | *** | *** | 5" | 4" | 50 AMR 16 | 1.300 | 2.100 | 2.300 | 16 |
| CE 90/45 | MULTI 35 6 | 3 | B 80-200 | E | 30 | ***** | *** | *** | 6" | 5" | 24 AMR 8 | 1.000 | 1.600 | 2.000 | 16 |
| CE 90/50 | MULTI 35 6 | 3 | B 65-200 | E | 30 | ***** | *** | *** | 6" | 5" | 24 AMR 8 | 900 | 1.300 | 1.700 | 16 |
| CE 90/55 | MULTI 35 6 | 3 | B 65-200 | E | 30 | ***** | *** | *** | 6" | 5" | 24 AMR 8 | 900 | 1.300 | 1.700 | 16 |
| CE 90/60 | MULTI 35 6 | 3 | B 65-200 | E | 40 | ***** | *** | *** | 6" | 5" | 24 AMR 8 | 1.000 | 1.600 | 2.000 | 16 |
| CE 90/65 | MULTI 35 6 | 3 | B 65-250 | E | 40 | ***** | *** | *** | 6" | 5" | 24 AMR 8 | 1.000 | 1.600 | 2.000 | 16 |
| CE 90/70 | MULTI 35 8 | 4 | B 65-250 | E | 40 | ***** | *** | *** | 6" | 5" | 50 AMR 10 | 1.000 | 1.600 | 2.000 | 16 |
| CE 90/75 | MULTI 35 8 | 4 | B 65-250 | E | 50 | ***** | *** | *** | 6" | 5" | 50 AMR 10 | 1.000 | 1.600 | 2.000 | 16 |
| CE 90/80 | MULTI 35 8 | 4 | B 65-250 | E | 50 | ***** | *** | *** | 6" | 5" | 50 AMR 10 | 1.000 | 1.600 | 2.000 | 16 |
| CE 90/85 | MULTI 35 8 | 4 | B 65-250 | E | 60 | ***** | *** | *** | 6" | 5" | 50 AMR 10 | 1.000 | 1.600 | 2.000 | 16 |
| CE 90/90 | MULTI 35 8 | 4 | B 65-250 | E | 60 | ***** | *** | *** | 6" | 5" | 50 AMR 10 | 1.000 | 1.600 | 2.000 | 16 |
| CE 90/95 | MULTI 35 10 | 5,5 | B 65-250 | E | 75 | ***** | *** | *** | 6" | 5" | 50 AMR 16 | 1.300 | 2.100 | 2.300 | 16 |
| CE 90/100 | MULTI 35 10 | 5,5 | B 65-250 | E | 75 | ***** | *** | *** | 6" | 5" | 50 AMR 16 | 1.300 | 2.100 | 2.300 | 16 |
| CE 100/45 | MULTI 35 6 | 3 | B 80-200 | E | 30 | ***** | *** | *** | 6" | 5" | 24 AMR 8 | 1.000 | 1.600 | 2.000 | 16 |
| CE 100/50 | MULTI 35 6 | 3 | B 80-200 | E | 40 | ***** | *** | *** | 6" | 5" | 24 AMR 8 | 1.000 | 1.600 | 2.000 | 16 |
| CE 100/55 | MULTI 35 6 | 3 | B 80-200 | E | 40 | ***** | *** | *** | 6" | 5" | 24 AMR 8 | 1.000 | 1.600 | 2.000 | 16 |
| CE 100/60 | MULTI 35 6 | 3 | B 65-200 | E | 40 | ***** | *** | *** | 6" | 5" | 24 AMR 8 | 1.000 | 1.600 | 2.000 | 16 |
| CE 100/65 | MULTI 35 6 | 3 | B 65-250 | E | 50 | ***** | *** | *** | 6" | 5" | 24 AMR 8 | 1.000 | 1.600 | 2.000 | 16 |
| CE 100/70 | MULTI 35 8 | 4 | B 65-250 | E | 50 | ***** | *** | *** | 6" | 5" | 50 AMR 10 | 1.000 | 1.600 | 2.000 | 16 |
| CE 100/75 | MULTI 35 8 | 4 | B 65-250 | E | 50 | ***** | *** | *** | 6" | 5" | 50 AMR 10 | 1.000 | 1.600 | 2.000 | 16 |
| CE 100/80 | MULTI 35 8 | 4 | B 65-250 | E | 50 | ***** | *** | *** | 6" | 5" | 50 AMR 10 | 1.000 | 1.600 | 2.000 | 16 |
| CE 100/85 | MULTI 35 8 | 4 | B 65-250 | E | 60 | ***** | *** | *** | 6" | 5" | 50 AMR 10 | 1.000 | 1.600 | 2.000 | 16 |
| CE 100/90 | MULTI 35 8 | 4 | B 65-250 | E | 60 | ***** | *** | *** | 6" | 5" | 50 AMR 10 | 1.000 | 1.600 | 2.000 | 16 |
| CE 100/95 | MULTI 35 10 | 5,5 | B 65-250 | E | 75 | ***** | *** | *** | 6" | 5" | 50 AMR 16 | 1.300 | 2.100 | 2.300 | 16 |
| CE 100/100 | MULTI 35 10 | 5,5 | B 65-250 | E | 75 | ***** | *** | *** | 6" | 5" | 50 AMR 16 | 1.300 | 2.100 | 2.300 | 16 |
| CE 110/45 | MULTI 35 6 | 3 | B 80-200 | E | 30 | ***** | *** | *** | 6" | 5" | 24 AMR 8 | 1.000 | 1.600 | 2.000 | 16 |
| CE 110/50 | MULTI 35 6 | 3 | B 80-200 | E | 40 | ***** | *** | *** | 6" | 5" | 24 AMR 8 | 1.000 | 1.600 | 2.000 | 16 |
| CE 110/55 | MULTI 35 6 | 3 | B 80-200 | E | 40 | ***** | *** | *** | 6" | 5" | 24 AMR 8 | 1.000 | 1.600 | 2.000 | 16 |
| CE 110/60 | MULTI 35 6 | 3 | B 80-200 | E | 50 | ***** | *** | *** | 6" | 5" | 24 AMR 8 | 1.000 | 1.600 | 2.000 | 16 |
| CE 110/65 | MULTI 35 6 | 3 | B 80-250 | E | 50 | ***** | *** | *** | 6" | 5" | 24 AMR 8 | 1.000 | 1.600 | 2.000 | 16 |
| CE 110/70 | MULTI 35 8 | 4 | B 80-250 | E | 50 | ***** | *** | *** | 6" | 5" | 50 AMR 10 | 1.000 | 1.600 | 2.000 | 16 |
| CE 110/75 | MULTI 35 8 | 4 | B 80-250 | E | 60 | ***** | *** | *** | 6" | 5" | 50 AMR 10 | 1.000 | 1.600 | 2.000 | 16 |
| CE 110/80 | MULTI 35 8 | 4 | B 80-250 | E | 75 | ***** | *** | *** | 6" | 5" | 50 AMR 10 | 1.100 | 1.800 | 2.100 | 16 |
| CE 110/85 | MULTI 35 8 | 4 | B 80-250 | E | 75 | ***** | *** | *** | 6" | 5" | 50 AMR 10 | 1.100 | 1.800 | 2.100 | 16 |

| EQUIPO | Bomba Auxiliar | | Bomba Servicio | | | Bomba Emergencia | | | Diámetro colector | Diámetro valvulería | Modelo calderín | DIMENSIONES | | | Ejecución |
|------------|----------------|-----|----------------|-------|-----|------------------|-------|-----|-------------------|---------------------|-----------------|-------------|-------|-------|-----------|
| | Modelo | HP | Modelo | Motor | HP | Modelo | Motor | HP | | | | A | B | C | |
| CE 260/75 | MULTI 35 8 | 4 | B 100-250 | E | 125 | ***** | *** | *** | 8" | 6" | 50 AMR 10 | 1.100 | 1.800 | 2.100 | 16 |
| CE 260/80 | MULTI 35 8 | 4 | B 100-250 | E | 137 | ***** | *** | *** | 8" | 6" | 50 AMR 10 | 1.100 | 1.800 | 2.100 | 16 |
| CE 260/85 | MULTI 35 8 | 4 | B 100-250 | E | 137 | ***** | *** | *** | 8" | 6" | 50 AMR 10 | 1.100 | 1.800 | 2.100 | 16 |
| CE 260/90 | MULTI 35 8 | 4 | B 100-250 | E | 150 | ***** | *** | *** | 8" | 6" | 50 AMR 10 | 1.100 | 1.800 | 2.100 | 16 |
| CE 260/95 | MULTI 35 10 | 5,5 | B 100-250 | E | 150 | ***** | *** | *** | 8" | 6" | 50 AMR 16 | 1.100 | 1.800 | 2.100 | 16 |
| CE 260/100 | MULTI 35 10 | 5,5 | consultar | | | ***** | *** | *** | 8" | 6" | 50 AMR 16 | | | | 16 |
| CE 280/45 | MULTI 35 6 | 3 | B 150-400 | E | 100 | ***** | *** | *** | 10" | 8" | 24 AMR 8 | 1.100 | 1.800 | 2.100 | 16 |
| CE 280/50 | MULTI 35 6 | 3 | B 150-400 | E | 110 | ***** | *** | *** | 10" | 8" | 24 AMR 8 | 1.100 | 1.800 | 2.100 | 16 |
| CE 280/55 | MULTI 35 6 | 3 | B 100-200 | E | 100 | ***** | *** | *** | 10" | 8" | 24 AMR 8 | 1.100 | 1.800 | 2.100 | 16 |
| CE 280/60 | MULTI 35 6 | 3 | B 100-200 | E | 110 | ***** | *** | *** | 10" | 8" | 24 AMR 8 | 1.100 | 1.800 | 2.100 | 16 |
| CE 280/65 | MULTI 35 6 | 3 | B 100-250 | E | 110 | ***** | *** | *** | 10" | 8" | 24 AMR 8 | 1.100 | 1.800 | 2.100 | 16 |
| CE 280/70 | MULTI 35 8 | 4 | B 100-250 | E | 125 | ***** | *** | *** | 10" | 8" | 50 AMR 10 | 1.100 | 1.800 | 2.100 | 16 |
| CE 280/75 | MULTI 35 8 | 4 | B 100-250 | E | 137 | ***** | *** | *** | 10" | 8" | 50 AMR 10 | 1.100 | 1.800 | 2.100 | 16 |
| CE 280/80 | MULTI 35 8 | 4 | B 100-250 | E | 137 | ***** | *** | *** | 10" | 8" | 50 AMR 10 | 1.100 | 1.800 | 2.100 | 16 |
| CE 280/85 | MULTI 35 8 | 4 | B 100-250 | E | 150 | ***** | *** | *** | 10" | 8" | 50 AMR 10 | 1.100 | 1.800 | 2.100 | 16 |
| CE 280/90 | MULTI 35 8 | 4 | B 100-250 | E | 150 | ***** | *** | *** | 10" | 8" | 50 AMR 10 | 1.100 | 1.800 | 2.100 | 16 |
| CE 280/95 | MULTI 35 10 | 5,5 | consultar | | | ***** | *** | *** | 10" | 8" | 50 AMR 16 | | | | 16 |
| CE 280/100 | MULTI 35 10 | 5,5 | consultar | | | ***** | *** | *** | 10" | 8" | 50 AMR 16 | | | | 16 |
| CE 300/45 | MULTI 35 6 | 3 | B 150-400 | E | 100 | ***** | *** | *** | 10" | 8" | 24 AMR 8 | 1.100 | 1.800 | 2.100 | 16 |
| CE 300/50 | MULTI 35 6 | 3 | B 150-400 | E | 110 | ***** | *** | *** | 10" | 8" | 24 AMR 8 | 1.100 | 1.800 | 2.100 | 16 |
| CE 300/55 | MULTI 35 6 | 3 | B 100-200 | E | 100 | ***** | *** | *** | 10" | 8" | 24 AMR 8 | 1.100 | 1.800 | 2.100 | 16 |
| CE 300/60 | MULTI 35 6 | 3 | B 150-400 | E | 125 | ***** | *** | *** | 10" | 8" | 24 AMR 8 | 1.100 | 1.800 | 2.100 | 16 |
| CE 300/65 | MULTI 35 6 | 3 | B 100-250 | E | 125 | ***** | *** | *** | 10" | 8" | 24 AMR 8 | 1.100 | 1.800 | 2.100 | 16 |
| CE 300/70 | MULTI 35 8 | 4 | B 100-250 | E | 125 | ***** | *** | *** | 10" | 8" | 50 AMR 10 | 1.100 | 1.800 | 2.100 | 16 |
| CE 300/75 | MULTI 35 8 | 4 | B 100-250 | E | 137 | ***** | *** | *** | 10" | 8" | 50 AMR 10 | 1.100 | 1.800 | 2.100 | 16 |
| CE 300/80 | MULTI 35 8 | 4 | B 100-250 | E | 137 | ***** | *** | *** | 10" | 8" | 50 AMR 10 | 1.100 | 1.800 | 2.100 | 16 |
| CE 300/85 | MULTI 35 8 | 4 | B 100-250 | E | 150 | ***** | *** | *** | 10" | 8" | 50 AMR 10 | 1.100 | 1.800 | 2.100 | 16 |
| CE 300/90 | MULTI 35 8 | 4 | B 100-250 | E | 150 | ***** | *** | *** | 10" | 8" | 50 AMR 10 | 1.100 | 1.800 | 2.100 | 16 |
| CE 300/95 | MULTI 35 10 | 5,5 | consultar | | | ***** | *** | *** | 10" | 8" | 50 AMR 16 | | | | 16 |
| CE 300/100 | MULTI 35 10 | 5,5 | consultar | | | ***** | *** | *** | 10" | 8" | 50 AMR 16 | | | | 16 |
| CE 320/45 | MULTI 35 6 | 3 | B 150-400 | E | 100 | ***** | *** | *** | 10" | 8" | 24 AMR 8 | 1.100 | 1.800 | 2.100 | 16 |
| CE 320/50 | MULTI 35 6 | 3 | B 150-400 | E | 110 | ***** | *** | *** | 10" | 8" | 24 AMR 8 | 1.100 | 1.800 | 2.100 | 16 |
| CE 320/55 | MULTI 35 6 | 3 | B 150-400 | E | 125 | ***** | *** | *** | 10" | 8" | 24 AMR 8 | 1.100 | 1.800 | 2.100 | 16 |
| CE 320/60 | MULTI 35 6 | 3 | consultar | | | ***** | *** | *** | 10" | 8" | 24 AMR 8 | | | | 16 |
| CE 320/65 | MULTI 35 6 | 3 | consultar | | | ***** | *** | *** | 10" | 8" | 24 AMR 8 | | | | 16 |
| CE 320/70 | MULTI 35 8 | 4 | consultar | | | ***** | *** | *** | 10" | 8" | 50 AMR 10 | | | | 16 |
| CE 320/75 | MULTI 35 8 | 4 | B 100-250 | E | 150 | ***** | *** | *** | 10" | 8" | 50 AMR 10 | 1.100 | 1.800 | 2.100 | 16 |
| CE 320/80 | MULTI 35 8 | 4 | B 100-250 | E | 150 | ***** | *** | *** | 10" | 8" | 50 AMR 10 | 1.100 | 1.800 | 2.100 | 16 |
| CE 320/85 | MULTI 35 8 | 4 | B 100-250 | E | 150 | ***** | *** | *** | 10" | 8" | 50 AMR 10 | 1.100 | 1.800 | 2.100 | 16 |
| CE 320/90 | MULTI 35 8 | 4 | consultar | | | ***** | *** | *** | 10" | 8" | 50 AMR 10 | | | | 16 |
| CE 320/95 | MULTI 35 10 | 5,5 | consultar | | | ***** | *** | *** | 10" | 8" | 50 AMR 16 | | | | 16 |
| CE 320/100 | MULTI 35 10 | 5,5 | consultar | | | ***** | *** | *** | 10" | 8" | 50 AMR 16 | | | | 16 |